

ITEM	PART NAME	MATERIAL	QTY
1	BODY	316L SST	1
2	SEAT INSERT	PCTFE	1
3	DIAPHRAGM ASSY.	316L SST/COPPER	1
4	BONNET	316L SST	1
5	STEM	416 SST	1
6	HANDLE	BLACK ABS PLASTIC	1
7	WASHER	18-8 SST	1
8	SCREW	18-8 SST	1
9	PANEL NUT	CHROME PLATED BRASS	1
10	LABEL	VINYL/MYLAR	1

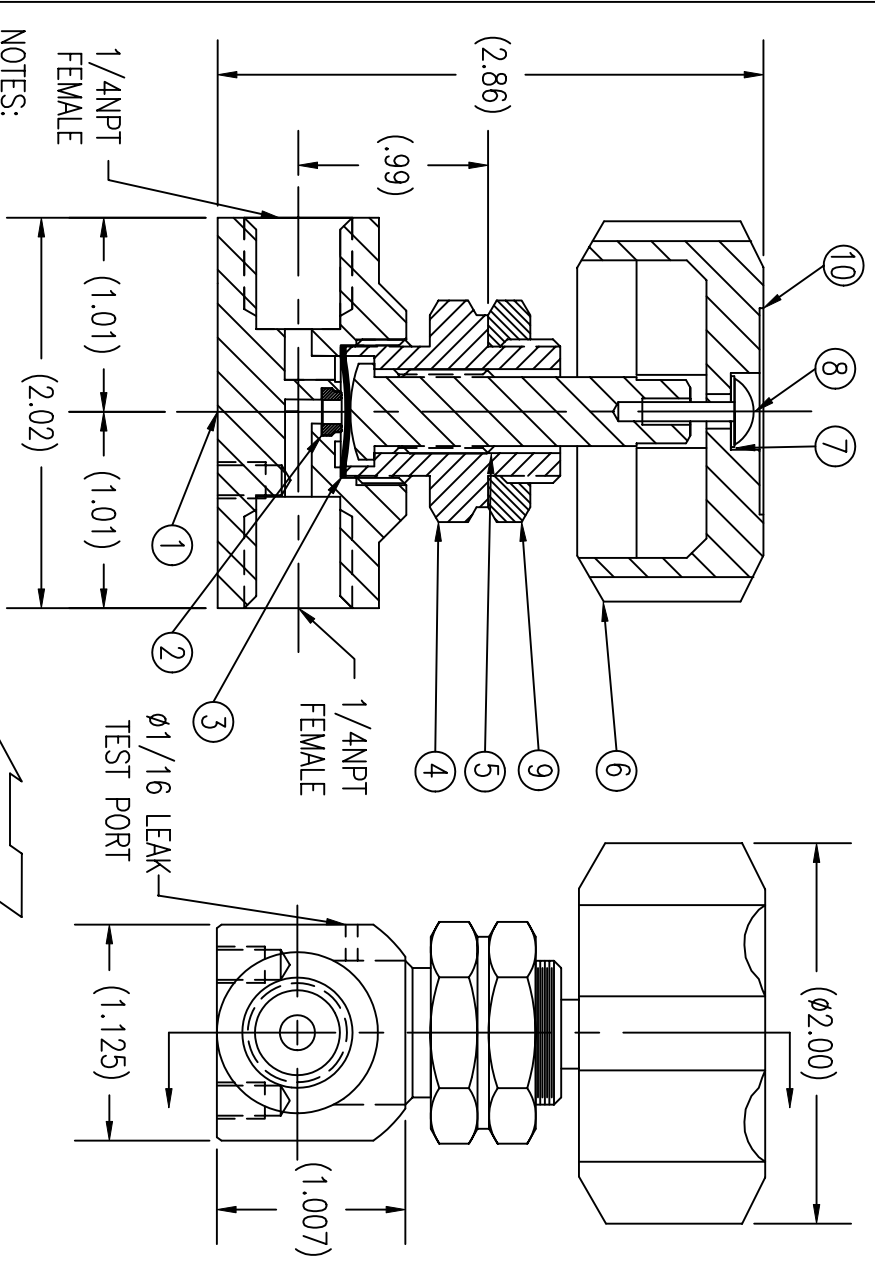

NOTES:
1. DIMENSIONS ARE IN INCHES.

DWN	MB	SCALE: 1:1
APPVD		DATE 2/1/02

GasFlo Products Inc.
Fairfield, N.J.

SALES DRAWING- PANEL MOUNT PACKLESS VALVE
SST BODY- 1/4 FNPT x 1/4 FNPT

UNCONTROLLED
For Reference Only
MB 3/30/2007

SPECIFICATIONS:
 PRESSURE RATING: 3500 PSI
 FLOW COEFFICIENT $C_v = .13$
 SEAT ORIFICE SIZE: $.125 \phi$
 SEAT MATERIAL: PCTFE
 TEMPERATURE LIMITS:
 -65° F TO 150° F
 MAX. ALLOWABLE SEAT LEAKAGE:
 2 x 10-8 ATM CC/SEC He
 MAX. INBOARD LEAKAGE:
 2 x 10-8 ATM CC/SEC He
 WETTED SURFACES: 316L SST,
 PCTFE.

THIS DOCUMENT CONTAINS INFORMATION THAT IS THE PROPRIETARY AND CONFIDENTIAL PROPERTY OF GASFLO PRODUCTS INC. AND MAY BE USED ONLY FOR AUTHORIZED PURPOSES. THIS DOCUMENT MAY NOT BE REPRODUCED WITHOUT GASFLO PRODUCTS INC. PRIOR WRITTEN CONSENT