

ITEM	PART NAME	MATERIAL	QTY
1	NUT	303 SST	1
2	NIPPLE	316L VIM/VAR SST	1

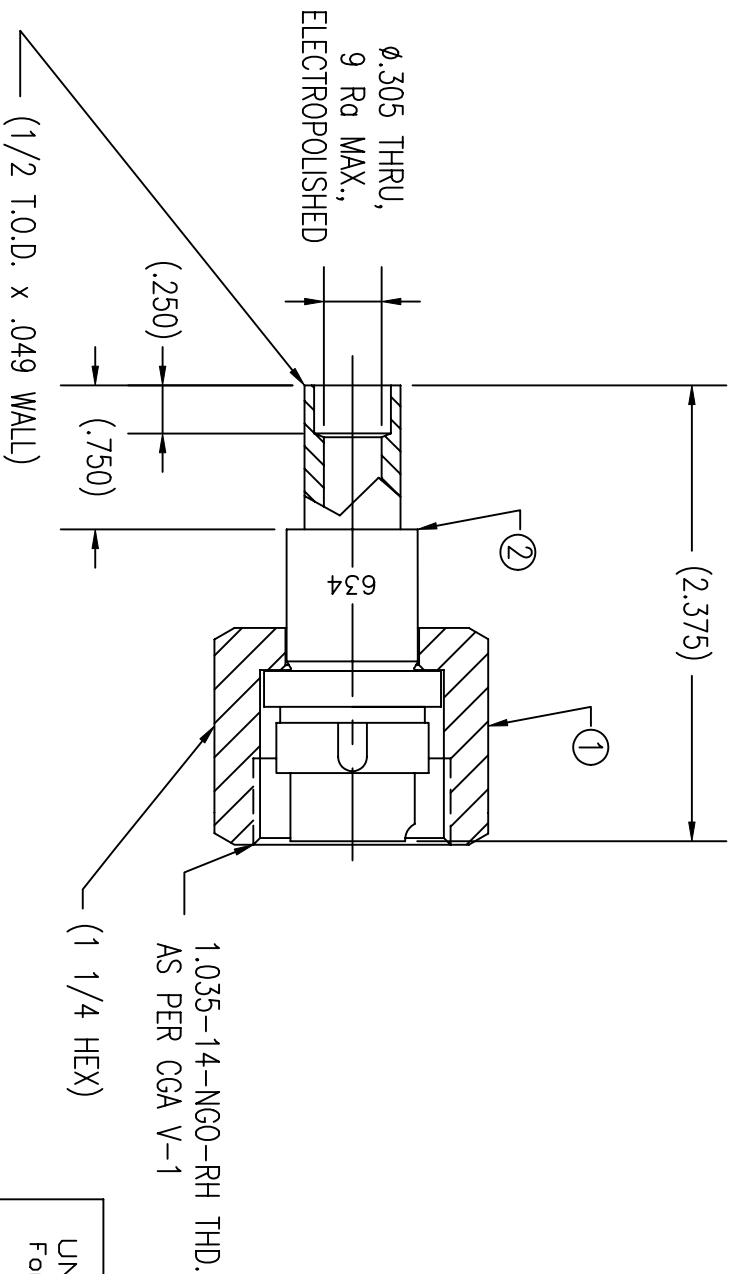

UNCONTROLLED
For Reference Only
MB 6/27/2011

NOTES:

1. NUT THREADS ARE SILVER PLATED.
2. ORDER PART NUMBER: INL-634SS-8TS. MAWP: 3000 PSI
3. NIPPLE IS D.I. ULTRACLEANED, NYLON INNER BAGGED AND POLY OUTER BAGGED.
4. NUT IS CLEANED FOR OXYGEN SERVICE AND SINGLE POLY BAGGED.
5. ASSEMBLY IS BULK POLY BAGGED AND LABELED WITH GFP LOGO AND GFP PART NUMBER.

GasFlo Products Inc.
Fairfield, N.J.

SALES DRAWING- INLET CONNECTION

CGA 634 x 1/2" TUBE STUB

THIS DOCUMENT CONTAINS INFORMATION THAT IS THE PROPRIETARY AND CONFIDENTIAL PROPERTY OF GASFLO PRODUCTS INC. AND MAY BE USED ONLY FOR AUTHORIZED PURPOSES. THIS DOCUMENT MAY NOT BE REPRODUCED WITHOUT GASFLO PRODUCTS INC. PRIOR WRITTEN CONSENT

DWN: MB
SCALE: NTS
APPVD: DATE: 6/27/11

DWG: SALES-INL-634SS-8TS